

Installation and Operation Manual

ITS pump kit 4A



its

International
Technology
Sourcing

solar division

OVERVIEW

Pump kit 4A is a top range pump kit for ITS evacuated and flat plate collectors. It runs of 220Vac and provides temperature differential pumping, tank over temperature protection, freeze protection and intelligent geyser element control. It also features a backlit LCD display showing the system status and temperatures.

Where to use: This kit is ideal for clients looking for a top range installation. It features easy installation, high performance and trouble free operation. Because the controller operates directly from mains power it is not ideal for areas where power failures during daytime are frequent and lengthy.

This kit consists of:

1. ITS-12Vdc pump.
2. SR868C6-12V solar controller
3. 30A geyser element relay with 12V coil
4. 15mm spring type non-return (check) valve
5. 220Vac to 12Vdc power supply.



Fig 1. Pump with non return valve connected, SR868C6-12V controller, geyser element relay and power supply.

INSTALLATION

Below is shown the system diagram of a typical installation using this pump kit. ITS recommends the use of a lever ball valve before the pump for easy servicing of the solar system. The pump must always be installed on the solar send (cold solar port) as close to the geyser as possible. The pump must also be under the water level of the geyser so that if the water supply to the geyser falls away the pump will not run dry. Always install anti-siphoning traps at the geyser to prevent heat from siphoning away from the geyser at night. Always install a non-return valve (check valve) after the pump to prevent superheated water from pushing back past the pump during collector stagnation.

ITS

International
Technology
Sourcing

A 220V plug point is required for the power supply. Please note that the SR868C6-12V is a modified version of the SR868C6-220V controller and therefore all the main power connection terminals are marked with N (neutral) and L (live). Since the controller is modified for 12Vdc operation the N terminals become the negative polarity and the L terminals become the positive polarity. It is important to observe this for the power connection to the controller and also the connection to the pump terminal P1. The cable from the controller to temperature sensors T1 and T2 can be extended using standard 0.75 mm ripcord. Please ensure that temperature sensor T1 is inserted properly into the solar collector temperature sensor pocket. Placing the sensor anywhere else (like tying it to the copper pipe outside the collector) will result in malfunctioning.

The SR868C6-12V controller has got a geyser element control function whereby it can switch on the geyser element during specified time windows if the water temperature is not at the desired temperature. To switch the high current 220V to the geyser element a relay is used (supplied with the kit). The controller H1 output is used to activate the relay to connect the 220V to the geyser element. The relay coil is not polarity sensitive.

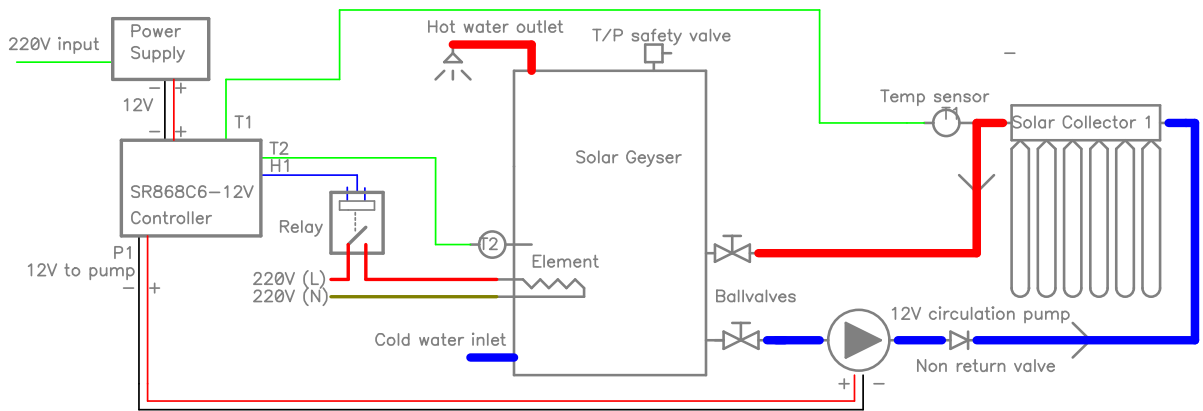

Fig 2. Wiring diagram.

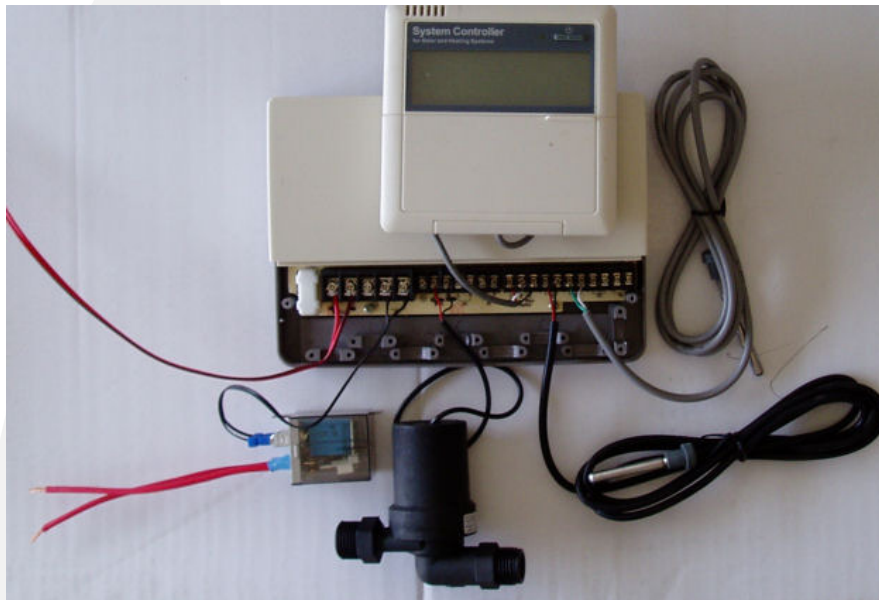

Fig 4. Wiring example.

its

International
Technology
Sourcing

solar division

COMMISSIONING

Firstly make sure that all trapped air has been bled out of the solar loop. When all the connections have been made and verified the power may be switched on. Check to see that the collector and tank temperatures look correct. The pump can be manually switched on by holding in the “Manual T” button for a few seconds and the switched off again by pressing this button again. The geyser element can be manually switched on by holding in the “Heating” button for a few seconds. Please note that this override function will not work if the geyser temperature is above 49 deg C. To deactivate the override function simply press the button again or alternatively the controller will deactivate it automatically when the tank temperature reaches 55 deg C. Please consult the SR868C6 quick start manual available on www.its-solar.com for recommend settings.

FAULTFINDING

Should a fault be suspected with the controller the following steps can be taken:

1. Verify the supply to the controller as well as the pump and temperature sensor connections.
2. If the pump is not running then use a voltmeter to verify the supply to the controller and also to check if there is power on the pump terminals. Also check the polarity of the supply and pump (a basic multimeter can do all this).
3. Consult the SR868C6 manual for further faultfinding info.

BASIC TECHNICAL SPECS

Product name	ITS 12Vdc pump
Power	±6W
Voltage	12Vdc
Max Temp	90°C
Max Pressure	600kPa
Head	2m
Flow rate	4 – 8 L/min
Port connections	15mm male

Product name	Non return valve
Type	Spring loaded
Pressure drop	
Port connections	15mm female
Max Temp	90°C

For the SR868C6 specification please consult the manual supplied with the controller.

its

International
Technology
Sourcing

solar division

LIABILITY WAIVER

The manufacturer cannot monitor the compliance with these instructions or the circumstances and methods used for installation, operation and utilization of this controller. Improper installation can cause damage to the solar system and personal injury. For this reason we do not take responsibility and liability for losses, damages or cost that might arise due to improper installation, operation or wrong utilization and maintenance or that occur in some connection with the aforementioned. The manufacturer preserves the right to make changes to the product, or installation and operation instructions without prior notice. As soon as it becomes evident that safe operation is no longer possible (e.g. visible damage), please immediately take the device out of operation.



International
Technology
Sourcing

solar division